

Installation Procedure

Last Updated: January 2025

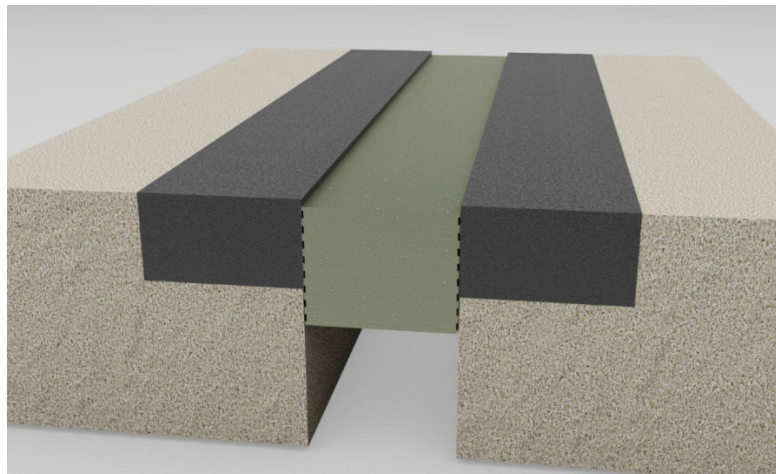

Wabo® XPE

Preformed impermeable, UV stable gray foam Joint Seal for Bridge & Highway Applications

The following installation procedure is very important and must be fully understood prior to beginning any work. To ensure proper installation and performance of expansion joint system the following actions must be completed by the installing contractor. Failure to do so will affect product warranty.

- 1) Carefully read and understand installation procedure. Contact WBA's Technical Service Department at (800) 677-4922 for product assistance.
- 2) Inspect all shipments and materials for missing or damaged components and hardware. Contact Customer Service at (800) 677-4922 with WBA's order number and invoice for prompt assistance.
- 3) Inspect substrate or adjacent construction for acceptance before beginning work. Report unacceptable construction to the project manager for scheduled repair work.
- 4) Review WBA shop drawings for project specific detailed information if Engineering services were purchased at time of order.

Information provided herein, including but not limited to, any drawing, design, photograph, graphic, or statement(s) ("Materials") are proprietary and the property of Watson Bowman Acme Corp. ("Company"). Reproduction, translation, or reduction to any electronic medium or machine readable form, in whole or part, is strictly prohibited, except for the express purpose for which it has been furnished, without prior written consent of Company. All Materials contained herein are provided by Company for information purposes only. Company reserves the right to amend or withdraw any information contained in the Materials without notice. All technical or other advice by Company, whether verbal or written, concerning products, or the use of products in specific situations ("Advice") is given by Company and is used at the User's own risk.

Health & Safety

During the installation of any Watson Bowman Acme product, appropriate personal protective items should be worn at all times, including but not limited to the following:

- Proper work clothing
- Safety glasses
- Safety boots
- Gloves
- Hard hat



Local rules and regulations regarding safe work environments and health should be followed.

Product Components

The following components are required for the installation of this product:



Drill

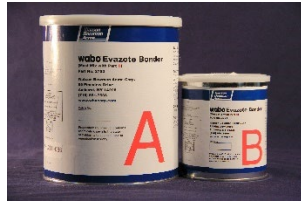

Wabo® Foam Seal Bonder
Gray

Pre-Installation Notes

The work shall consist of furnishing and installing a Wabo®XPE joint seal in accordance with the details shown on the plans and the requirements of the specifications. Placement of the Wabo®XPE joint seal shall consist of proper surface preparations, material and application of materials. The Wabo®XPE joint seal shall be shipped in 50' continuous length pieces in manufacturer's standard shipping carton. Wabo®FoamSeal Bonder will be shipped in manufacturer's labeled containers. Seals shall be cut to length on jobsite where required. Miter cut or bend seal (depending on size) in the field to conform to directional changes unless otherwise contracted with expansion joint manufacturer.

Joint Preparation

- Forming materials should be carefully removed to avoid edge spalling of the concrete. Joint gap edges should be chamfered to help prevent small fractures and spalling. Edge spalling conditions should be repaired and allowed to properly cure prior to installation of the Wabo®XPE. Repairs shall be made as directed by the Engineer.
- The concrete sidewalls must be sound and free of all contaminants such as grease, oil, form release agents, etc. prior to installation of the Wabo®XPE.



Watson Bowman Acme
95 Pineview Drive
Amherst, NY 14228
Phone: 716-691-7566
Fax: 716-691-9239
watsonbowmanacme.com



SIKA CORPORATION
201 Polito Avenue
Lyndhurst, NJ 07071 USA
Phone: +1-800-933-7452
Fax: +1-2019336225
www.usa.sika.com

- The preferred method of surface preparation to produce laitance-free, roughened sidewalls is abrasive blasting. Where this is not permitted, disc grinding should be employed. Ensure a coarse disc is used to produce an abraded surface. The gap openings should be blown out with clean air to remove dust.
- Installation must be performed in joint gap openings with sound, clean and dry substrates. Any loose portion of concrete at the gap must be removed and the concrete properly repaired as directed by the engineer.

Preparation (New or Aged Concrete)

- The concrete substrate must be clean (free of dirt, coatings, rust, grease, oil and other contaminants), sound and durable. New concrete must be cured (minimum of 14 days) and all laitance removed. Suitable preparation methods include sandblasting, chipping and scarification. Acid etching is not encouraged, although it may be required.
 - Durable Concrete - Sound and durable concrete should have a cap pull-off strength that meets or exceeds ACI 503R, Appendix A.
 - Unsound Concrete – Loose, contaminated, weak, spalled, deteriorated and/or delaminated concrete must be removed to sound concrete and repaired prior to placement of Wabo®Crete II elastomeric concrete.

Preparation (Steel – New or Existing)

- Steel surfaces must be abrasive blasted immediately prior to installing the Wabo®XPE profile. This is a requirement in new or existing construction. All oxidation must be removed and “white steel” revealed. Where abrasive blasting is not permitted, steel surfaces will be aggressively disc-ground to roughen and abrade the surface to achieve the “white steel” condition.
- Stainless steel surfaces require aggressive grinding and blasting to remove the smooth, glassy surface for acceptable installations. On galvanized steel surfaces, the galvanizing material must be removed to look like “white steel.”

Seal Placement

1

Prior to installation, the profile shall be uncoiled from shipment packaging and allowed to reach a relaxed condition. The Wabo®XPE profile shall be cut to the correct length for installation. Care should be taken to extend the profile to its full length, without exerting any tension or stretching of the seal.

2

Measure the joint opening width. Seal material should be sized 25% larger than the joint opening at near neutral, but never less than 16% oversized or greater than 38% oversized.



Watson Bowman Acme
95 Pineview Drive
Amherst, NY 14228
Phone: 716-691-7566
Fax: 716-691-9239
watsonbowmanacme.com



SIKA CORPORATION
201 Polito Avenue
Lyndhurst, NJ 07071 USA
Phone: +1-800-933-7452
Fax: +1-2019336225
www.usa.sika.com

Mixing of Wabo® FoamSeal Bonder

3

Separately mix Wabo® FoamSeal Bonder components A and B separately. For smaller batches, mix 3 parts of component A with 1 part of component B in a clean plastic pail. Mix for approximately 3 minutes or until there is no marbling. Care should be taken to mix only what will be applied within the given pot life of the batch. Warmer weather, as well as larger batches, will decrease the pot life of the mixed material. The two-component epoxy adhesive should be thoroughly mixed until a uniform color result.

Seal Installation

If splicing is required, start at splice location, working your way outwards.

4

Apply mixed Wabo® FoamSeal Bonder by brush, trowel, caulking gun or by hand with rubber gloves. Apply enough to coat the substrate to an approximate thickness of 40 mils (1mm). Continue applying the Wabo® FoamSeal Bonder on both surfaces, working it in the direction ahead of the joint material not more than 20 feet (6 m) ahead. Next, apply the Wabo® FoamSeal Bonder to both sides of the joint material. Apply enough to coat and fill the grooves, approximately 40 mils (1 mm).

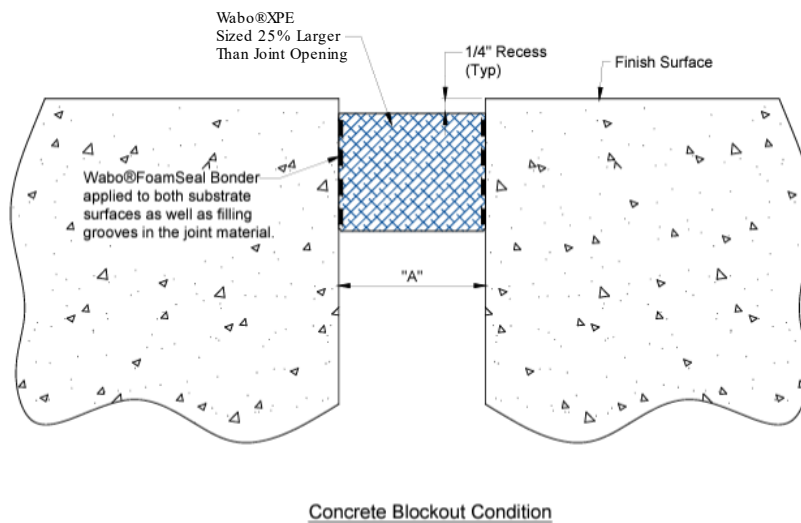

5

Install the coated seal material where the Wabo® FoamSeal Bonder was initially applied on the substrate. The joint material should be installed approximately 1/4" (6mm) below the joint edge and should not protrude above the joint edge. Continue installation of the seal in the same direction as the Wabo® FoamSeal Bonder was initially applied. DO NOT push at an angle or pull the material, as this will stretch the material.

6

With gloved hands, compress the material and with the help of a blunt probe push down into the joint until it is recessed approximately 1/4" (6mm) below the surface. Clean all excess epoxy from the edges of the joint and from the top of the seal as soon as it is pushed into the desired depth. DO NOT allow the Wabo® FoamSeal Bonder to cure before removing it. Use a clean trowel or a putty knife tilted at an angle opposite the

direction of application. DO NOT allow any epoxy bonder near any area to be cut and welded until the weld is completed, or the weld will not hold.

- 7 Allow the Wabo®FoamSeal Bonder to set approximately 20 minutes @77F (25C) before traffic is allowed onto the joint. Slightly longer times are required during cooler weather. When a continuous joint cannot be finished, the epoxy bonder on the substrate and also on the joint material must end evenly. Install the joint past the epoxied surfaces at least 6 to 12 inches (150-300mm) dry or without epoxy. This can be pulled out later to be re-welded and the installation continued.

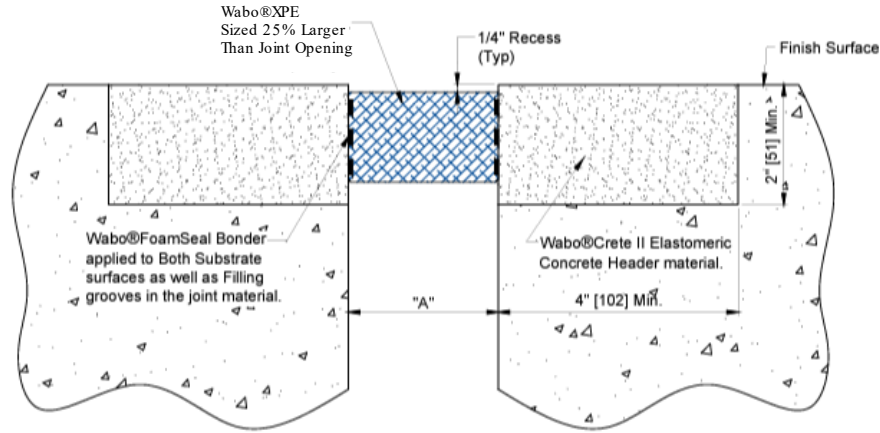

Wabo@XPE in WaboCrete@II
Elastomeric Concrete

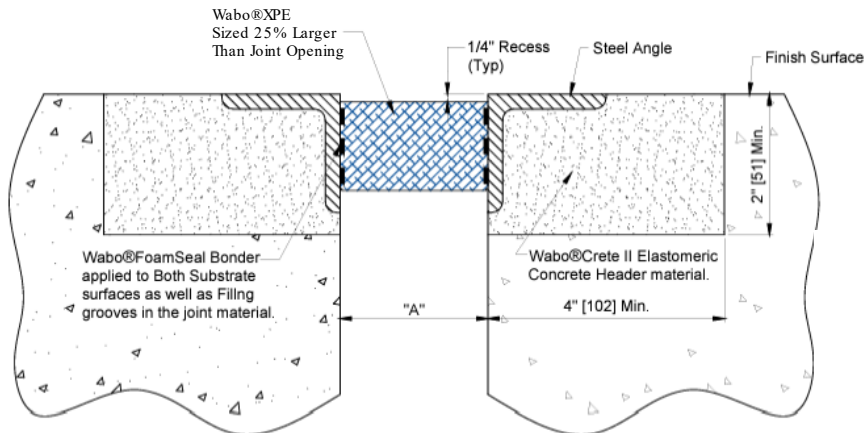

Wabo@XPE in Armored Edge Condition
w/WaboCrete@II Elastomeric Concrete

Splice Procedure

If splicing is required, start at splice location, working your way outwards.

8 The bond at the splice location is achieved by heat welding. Heat welds, splices and other directional changes should be cut and made prior to seal installation. Ensure that the surfaces to be bonded together are both smooth so that full bearing contact can be achieved. Using a miter box and backsaw with no teeth, cut seal ends square. Preheat heat plate to 425 degrees, approximately five minutes. Touch the heat plate. Leave the gland touching the heat plate for about 1-2 minutes. Remove seals. Once edges have been aligned, apply enough pressure to cause the ends of the seal to slightly protrude upwards. Allow approximately 3 to 4 minutes of cure time prior to releasing pressure.

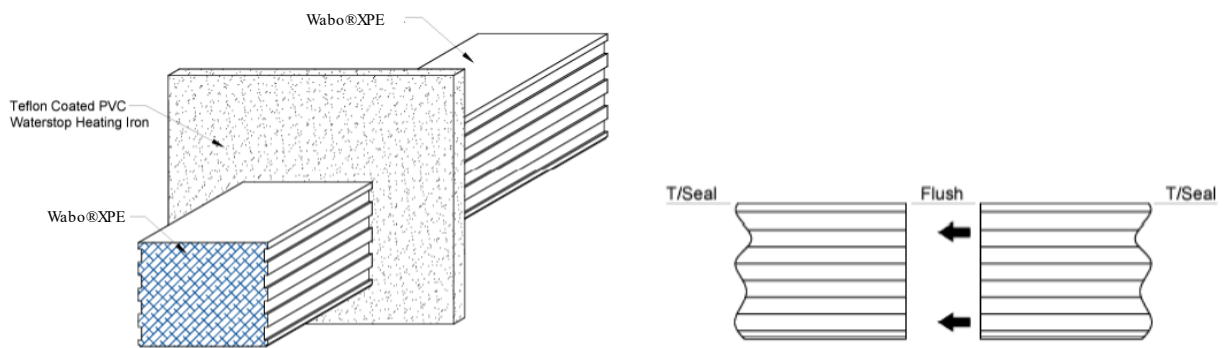

9 **Directional changes:** heat welds are not required for all turns. For vertical turns, the maximum angle the joint material can sustain without heat welding is 115 degrees. For horizontal turns, the maximum angle the joint material can sustain without heat welding is 135 degrees. Heat welds will add to the aesthetics of an installation and are required for 90 turns.

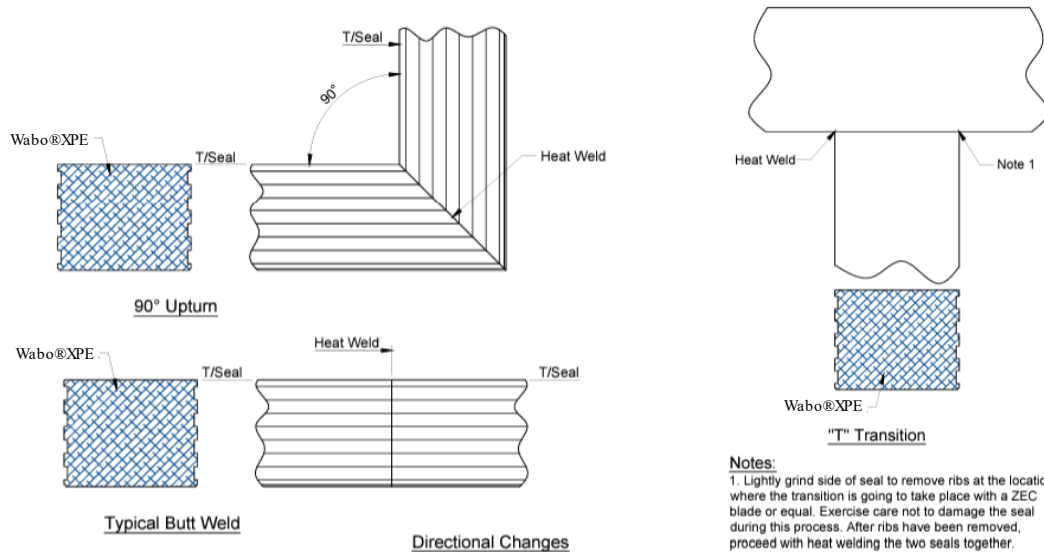



Follow us on social media for industry news, new product announcements & more:



Watson Bowman Acme
95 Pineview Drive
Amherst, NY 14228
Phone: 716-691-7566
Fax: 716-691-9239
watsonbowmanacme.com



SIKA CORPORATION
201 Polito Avenue
Lyndhurst, NJ 07071 USA
Phone: +1-800-933-7452
Fax: +1-2019336225
www.usa.sika.com