

Wabo® CompressionSeal- CALTRANS- Type B

Bridge Series

Features	Benefits
<ul style="list-style-type: none"> • Long proven track record 	Cost effective solution with over 30 years history of success
<ul style="list-style-type: none"> • Ease of installation 	Wabo®PrimaLub lubricant facilitates the installation of the system
<ul style="list-style-type: none"> • Versatile 	Conforms to various structural configurations
<ul style="list-style-type: none"> • Unique design 	Proven profile design provides uniform compression and prevents the seal from being forced out of the joint opening

DESCRIPTION:

Wabo®CompressionSeal bridge series is a preformed neoprene elastic joint seal manufactured of neoprene and installed with a lubricant adhesive. It is highly resistant to deterioration from exposure to weather, sunlight, oils and impact. When properly installed, the Wabo®CompressionSeal bridge series provides a permanent seal for any type construction whether in bridges, parking decks, or buildings.

Featuring an internal elastomeric cross-sectional web configuration, the seal design allows it to exert a continuous and uniform force against the joint walls therefore effectively preserving water tightness. Even at the lowest design temperature, the seal will retain its elasticity while maintaining a minimum of 15% compression to assure a dependable seal. The Wabo®CompressionSeal bridge series has proven itself to be an effective and efficient seal in resisting the differential movements and extreme conditions found in high impact structures.

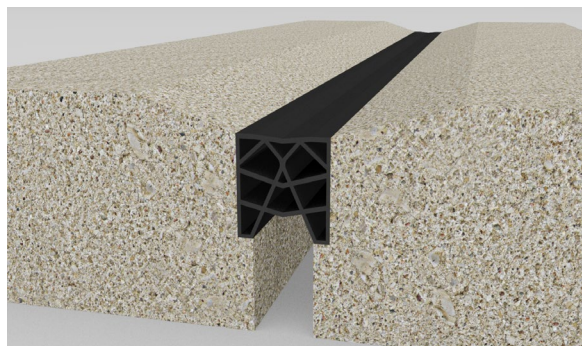

RECOMMENDED FOR:

- Sealing expansion joints on bridge and highway structures
- Heavy duty traffic and high load applications
- On-call maintenance and rehabilitation

PACKAGING/COVERAGE:

- Depending on seal size, the longest available stock lengths or ordered lengths are provided
- Wabo® CompressionSeal seals are cut to length and palletized per limitations of required shipping methods.
- Wabo® PrimaLub – 1 gal container
- Wabo® PrimaLub lubricant coverage will depend on joint size, placement, waste, and experience.
- Wabo® PrimaLub consumption guidelines
 - 1.25" to 3.5" seal width = 200 ft per gallon
 - > 3.5" seal width = 100 ft per gallon

SEAL	ROLL LENGTH
Wabo® Compression Seal WA-175	1000 ft
Wabo® Compression Seal WA-225	500 ft
Wabo® Compression Seal WA-375	550 ft
Wabo® Compression Seal WA-500	300 ft
Wabo® Compression Seal WA-600 (special order)	300 ft

TECHNICAL DATA:

Design Information

The degree of slab movement and actual joint width should be known before the appropriate sized Wabo® Compression Seal can be selected for a particular joint. Any variation in joint openings as well as creep and shrinkage should also be considered.

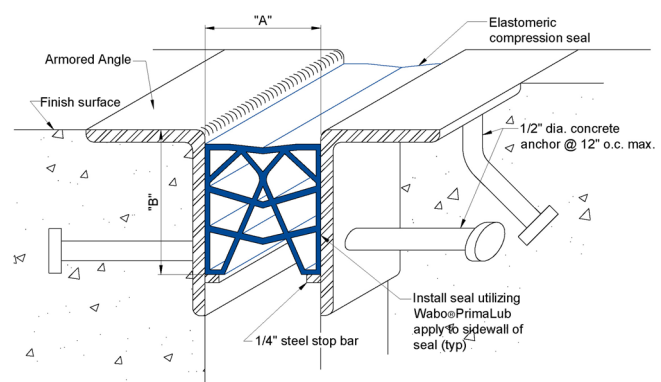
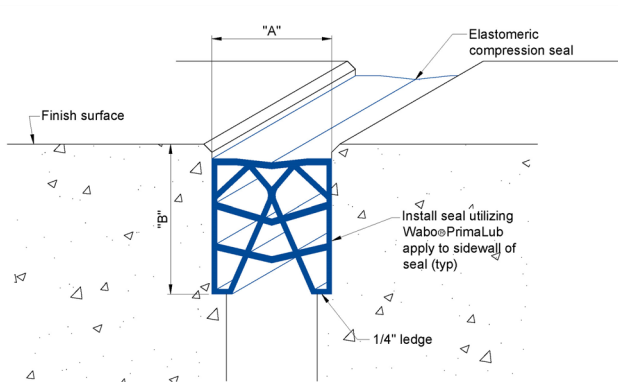

Movement Table

Model Number	Groove Width "A"						Min. Install Width	Groove Depth "B"		Nominal				
	Min.		Max.		Total					Width		Height		
	in	mm	in	mm	in	mm		in	mm	in	mm	in	mm	
WA-175	.67	17	1.49	38	.80	20	1.00	25	2.63	67	1.75	44	1.63	41
WA-275	1.00	25	2.33	59	1.33	34	1.63	41	3.13	79	2.75	70	2.63	67
WA-375	1.72	44	3.30	84	1.58	40	2.38	60	4.25	108	3.88	98	3.75	95
WA-500	1.63	41	4.25	108	2.63	67	3.00	76	5.50	140	5.00	127	5.00	127
WA-600	2.00	51	5.10	130	3.10	79	3.50	89	6.50	165	6.00	152	6.00	152

PHYSICAL PROPERTIES:

Wabo® CompressionSeal seal material complies with ASTM D2628 and ASTM D3542 and AASHTO M297

PHYSICAL PROPERTY	ASTM TEST METHOD	REQUIREMENTS
Tensile Strength, min	D 412	2,000 psi (13.8 Mpa)
Elongation at Break, min	D 412	250%
Hardness, Shore A	D 2240	55 +/- 5
Oven Aging, 70 hrs. @ Tensile, max loss Elongation, max loss Change in Hardness	D 573	20% 20% 0 to 10 pts.
Oil Swell, 70 hrs. @212°F(100°C) Weight Change, max	D 471	45%
Ozone Resistance 70 hrs. @104°F(40°C)	D 1149	no cracks
Low Temperature Recovery 72 hrs 14°F, min 22 hrs -20°F, min 70 hrs 212°F, min	Section 7d	88% 83% 85%

INSTALLATION SUMMARY:

- The joint opening must be abrasive blasted to remove all latencies and contaminants which may cause bonding problems. If abrasive blast not available wire wheel prep and wipe clean.
- Measure and cut to exact length needed for continuous joint, being careful not to pull or stretch the seal.
- The seal should be installed below the finished surface and should never protrude above the joint edge. See the movement chart for proper groove depth.
- Wear appropriate safety gloves when handling Wabo®PrimaLub. Apply a thin film of Wabo®PrimaLub lubricant immediately prior to the installation of the Wabo®CompressionSeal. Wabo®PrimaLub lubricant should be applied to both sides of the seal and along the joint interfaces.
- Compress seal and insert into joint opening. Clean the excess lubricant from the top surfaces.

FOR BEST RESULTS:

- Install when concrete substrate is clean, sound, dry, and cured (14 day minimum).
- Do not install if the joint's anticipated movement will exceed the seal's movement range. Do NOT use on joints where movements exceed 3 inches.
- Protect the work area with appropriate plastic sheeting.
- Minimize splice points by installing seals in longest possible continuous lengths.
- Do not allow any of the components to freeze prior to installation. Store all components out of direct sunlight in a clean, dry location between 50°F and 90°F.
- Shelf life of unopened chemical components is 1 year.
- Periodically inspect the applied material and repair localized areas as needed. Consult a Watson Bowman Acme representative for additional information.

- Make certain the most current version of the product data sheet is being used. Please consult the website (www.watsonbowmanacme.com) or contact a customer service representative.
- Proper application is the responsibility of the user. Field visits by Watson Bowman Acme personnel are for the purpose of making technical recommendations only and not for supervising or providing quality control on the jobsite.

OPTIONS/EQUIPMENT:

- Seal installation tool (pogo stick) is recommended for installation. Contact WBA for seal installation tool.

RELATED DOCUMENTS:

- Material Safety Data Sheets
- Wabo[®]CompressionSeal Specification
- Wabo[®]CompressionSeal Sales Drawings
- Wabo[®]CompressionSeal Installation Procedure

LIMITED WARRANTY:

Watson Bowman Acme Corp. warrants that this product conforms to its current applicable specifications. WATSON BOWMAN ACME CORP. MAKES NO OTHER WARRANTY, EXPRESS OR IMPLIED, INCLUDING ANY WARRANTY OF MERCHANTABILITY OR WARRANTY OF FITNESS FOR A PARTICULAR PURPOSE. The sole and exclusive remedy of Purchaser for any claim concerning this product, including, but not limited to, claims alleging breach of warranty, negligence, strict liability or otherwise, is the replacement of product or refund of the purchase price, at the sole option of Watson Bowman Acme Corp. Any claims concerning this product shall be submitted in writing within one year of the delivery date of this product to Purchaser and any claims not presented within that period are waived by Purchaser. IN NO EVENT SHALL WATSON BOWMAN ACME CORP. BE LIABLE FOR ANY SPECIAL, INCIDENTAL, CONSEQUENTIAL (INCLUDES LOSS OF PROFITS) OR PUNITIVE DAMAGES. Other warranties may be available when the product is installed by a factory trained installer. Contact your local Watson Bowman Acme representative for details. The data expressed herein is true and accurate to the best of our knowledge at the time published; it is, however, subject to change without notice.

WaboCompressionSeal-Bridge_CALTRAN_1124